

INSPECTION

1. INSPECT HORN SWITCH

- (a) Check that no continuity exists between terminal 6 of the connector and body ground.
- (b) Check that continuity exists between terminal 6 of the connector and body ground when the horn contact plate is pressed against the steering spoke assembly.

If continuity is not as specified, repair or replace the steering wheel or wire harness as necessary.

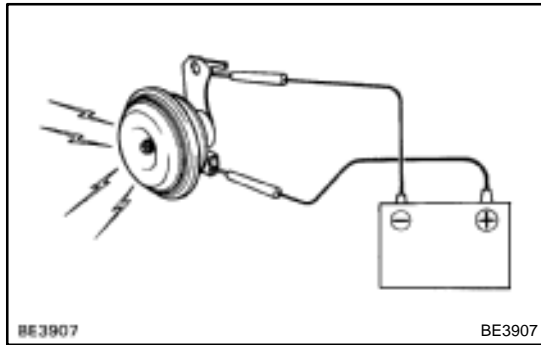

2. INSPECT HORN OPERATION

Connect the positive (+) lead from the battery to the terminal and negative (-) lead to the horn body and check that the horn blows.

If operation is not as specified, replace the horn.

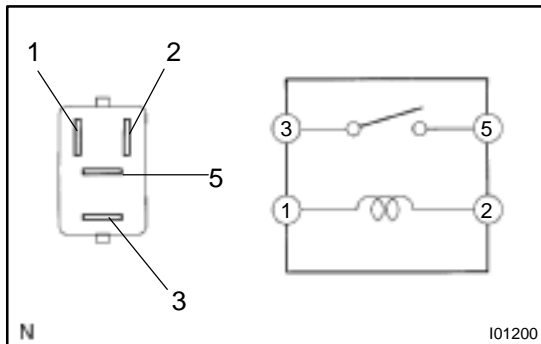

3. INSPECT HORN RELAY CONTINUITY

Condition	Tester connection	Specified condition
Constant	1 - 2	Continuity
Apply B+ between terminals 1 and 2.	3 - 5	Continuity

If continuity is not as specified, replace the relay.